

REFRIGERATORS FOR MILK STORAGE CENTER COOLER

INSTALLATION, USE AND SERVICE MANUAL

ORIGINAL INSTRUCTION



CONTENTS

1. Purpose of This Manual
2. Safety Warnings
3. Manufacturer Identification
4. Product Identification
5. General Description
6. Description of Operation
7. Installation and Use
 - 7.1 Checking the packaging
 - 7.2 Positioning
 - 7.3 Electrical connection
 - 7.4 Use
 - 7.5 Defrosting
 - 7.6 Installation of milk tube
 - 7.7 Cleaning and maintenance
 - 7.8 Non-ordinary maintenance and servicing
8. Disposal
9. Warranty Claims
10. Troubleshooting

1 Purpose of This Manual

This manual for the WMF Center Cooler refrigerator, serves to provide instructions and useful recommendations for the correct installation, start up, use, maintenance and cleaning of the appliance as well as to point out any residual risks or risks arising from incorrect use.

This manual must be considered an integral part of the appliance to which it refers and as such, it needs to be kept with care.

Some figures in this manual may illustrate details or parts that differ slightly from those on your appliance; this in no way modifies essential information.

The manufacturer reserves the right to update this manual, as considered necessary, at any time and without notice.

2 Safety Warnings

The safe and correct use of this product requires you to follow the rules and guidelines in this manual. The manufacturer cannot be held liable for any damage arising from failure to abide by the warnings in this manual.

The product referred to in this manual is made to store milk for human consumption. No use other than that for which it was intended is permitted. Any other use is considered improper and therefore, hazardous.

Warnings and important safety Instructions in this manual do not cover all possible conditions and situations that may occur. It is your responsibility to use common sense, caution, and care when installing, maintaining, and operating your appliance.

Carefully read the labels on the refrigerator; do not cover them under any circumstances and be sure to replace them immediately should they become damaged.

R600a (flammable gas) is used as a refrigerant. You will find this label on the compressor.



In this case, some special precautions must be taken:

- to reduce flammability hazards the installation of the appliance must only be carried out by a suitably qualified person.
- place the refrigerator in a well sized ambient.
- handle the device paying attention in order to do not to increase the risk of refrigerant loss.
- when positioning the appliance, ensure the supply cord is not trapped or damaged.
- do not locate multiple portable socket-outlets or portable power supplies at the rear of the appliance.
- do not damage the refrigerant circuit.
- do not use the refrigerator if it seems to be damaged.
- to avoid damages on refrigeration circuit, do not use mechanical devices or any other means to accelerate the defrosting process.
- keep ventilation openings always free.
- if refrigerant leaks from the pipe, avoid any naked flames and move anything flammable away from the product and ventilate the room immediately.
- do not use electrical appliances inside the food storage compartments of the appliance, unless they are of the type recommended by the manufacturer.
- do not store explosive substances such as aerosol cans with a flammable propellant in this appliance.
- the components must be replaced by the same components and suitable for specific use, maintenance must be carried out only by specialized and authorized personnel to minimize the risk of possible explosions due to incorrect components or improper maintenance.

In case of malfunctioning, disconnect the refrigerator from the power supply immediately.

If the power cable is damaged, it needs to be replaced by the assistance servicing or authorized person.

Non-routine maintenance operation must be performed only by professionally qualified persons.

Some points of the internal condensing unit of the refrigerator may be hot or have potentially sharp edges.

Before carrying out non-routine maintenance or servicing operation, disconnect the power supply and wait for the time needed for the appliance to cool down. Always wear suitable personal protective equipment, compliant with current standards, when performing cleaning or maintenance.

The “Electric Shock Hazard” label found on parts, casings and/or covers serves to warn that their removal means being exposed to the danger of coming into contact with energised parts.



Do not expose the refrigerator to jets of water and never use toxic substances for cleaning.

Do not expose the refrigerator to sources of heat.

In case of fire, use extinguisher powder.

The packaging material must be disposed in compliance with current regulations.

3 Manufacturer Identification

The product referred to in this manual is designed and made by

Vitrifrigo s.r.l.

Via Giuseppe Mazzini, 75 – Fraz. Montecchio

61022 Vallefoglia (PU) - Italy

Tel. +39 0721 154500

Fax +39 0721 497739

Mail info@vitrifrigo.com

4 Product Identification

Each refrigerator has an identification label with the following information:

- model
- unit identification code and serial number
- refrigerated compartment volume (or milk container volume)
- climatic class
 - N: functioning from 16°C up to 32 °C ambient temperature*
 - 4: functioning up to 30 °C ambient temperature and 55% rH*
- compressor model
- power supply voltage and power frequency
- total current consumption of the refrigerator
- refrigerant type and quantity
- expanding gas for the insulation foam
- LP/HP pressures (only for USA products)

5 General Description

The product referred to in this manual is expressly designed to be coupled with WMF coffee machines for the guaranteeing the correct storage of milk at a controlled temperature.

NOTE: refrigerator has not been designed to cool down the milk from the ambient temperature (or above).

The max weight of the device (with its milk container) is 21 kg.

The A-weighted emission sound pressure level of the appliance is below 70 dB(A).

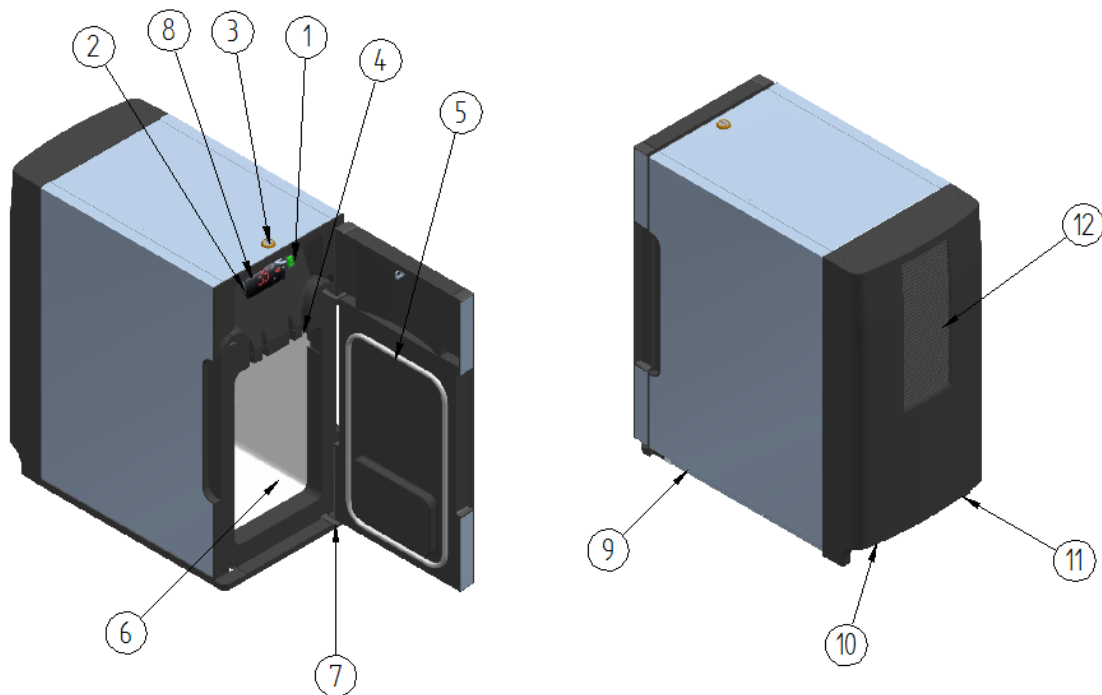

Fig.1

1-Main power switch	7-Door hinge
2-Digital thermostat	8-Inlet air ventilation
3-Key lock	9-Feet
4-Milk tube slot	10-IEC power plug
5-Removable gasket	11-Milk sensor plug
6-Inner liner	12-Outlet air ventilation

6 Description of Operation

The refrigerator operates using a refrigerant vapour compression cycle that transfers heat from the inside to the outside, making it possible to keep the liquid for human consumption stored inside it at a constant, pre-set temperature.

The refrigerant evaporates by removing the heat from the air via the cold inside walls of the refrigerator (in contact with the evaporator through which it flows) before entering the compressor. Here the pressure and temperature of the refrigerant are increased, and it is then passed through an air-cooled condenser, where it is condensed. Lastly, the refrigerant fluid returns inside the evaporator via capillary and the cycle is repeated.

The internal temperature can be varied using the digital thermostat in the frontal part of the refrigerator.

7 Installation and Use

7.1 Checking the packaging

As soon as the package arrives, inspect it, making sure that it is not upturned and that it has suffered no damage during transport. Remove the packaging and inspect the unit for damage of any kind.

If there is any doubt as to the integrity of the system parts, do not use the refrigerator.

You must inform your dealer of any damage and/or anomalies not later than 24 hours from the delivery date.

7.2 Positioning

The refrigerator has the overall dimensions in millimetres (in inches) shown in the figure below.

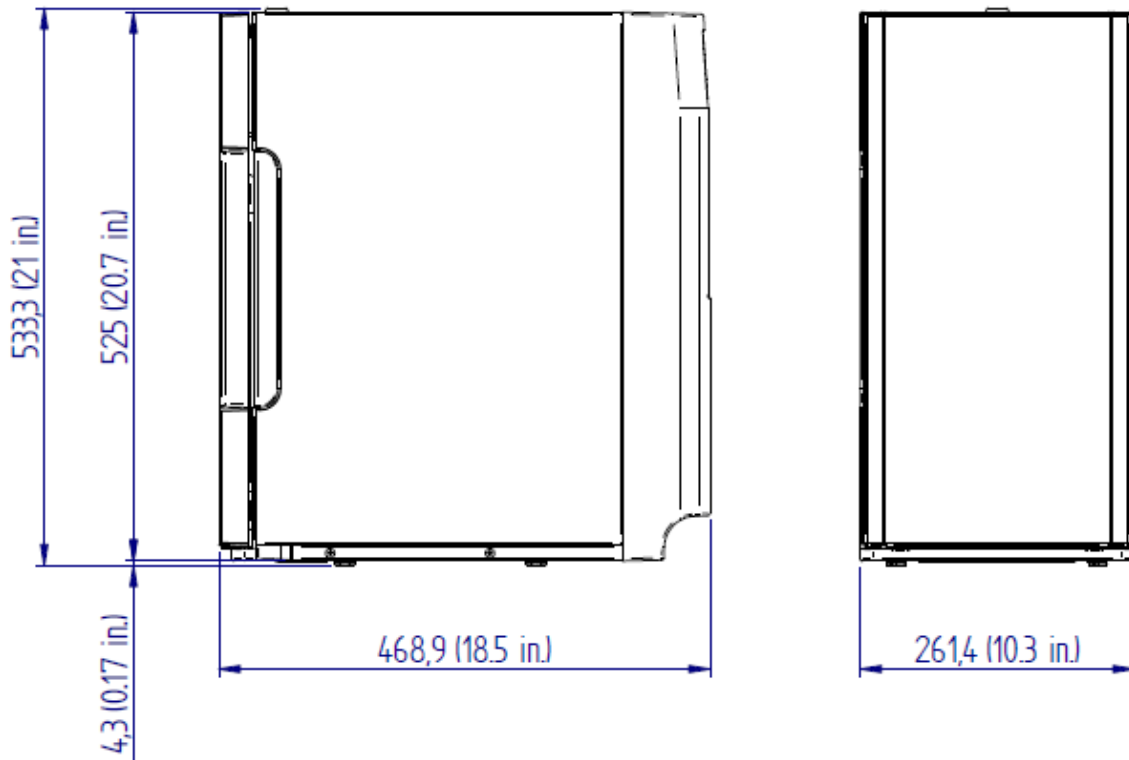

Fig.2

Place the refrigerator on a horizontal surface.

When choosing the position of the refrigerator, remember that a gap of at least 100 mm (4 in.) is required between the back panel of the refrigerator and any wall to allow the warm air from condensation to escape.

We recommend leaving a gap of the same size 100 mm (4 in.) between the top part of the refrigerator and any surface above it.

As far as any space requirements at the sides of the refrigerator are concerned, there are no specific instructions.

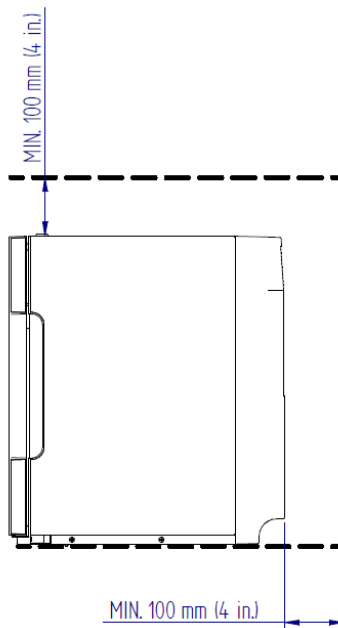

Fig.3

7.3 Electrical connection

The refrigerator is equipped with an IEC connection socket and a main power switch on the frontal panel.

The power cord with the proper plug for the country where it will be used is supplied with the refrigerator.

Before connecting the refrigerator to the main electrical line, make sure that the supply has the same characteristics (voltage, number of phases, network frequency and amperage) as those stated on the product label.

Grounding the appliance is obligatory and therefore you must ensure that the electrical system to which the refrigerator will be connected is grounded and that the grounding system is in perfect working order.

The manufacturer declines all liability for any damage suffered by people or property as a result of failure to abide by the above instructions.

To connect the refrigerator to the main electrical line, insert the plug into a socket without using, if possible, adaptors, multiple sockets and/or extension cords. Should the use of any of these accessories be unavoidable, only use items that comply with current safety standards and take care never to exceed their capacity (in current).

7.4 Use

The refrigerator has slots on the frontal part for ducting the pipe to pick up milk from the container placed inside the refrigerator.

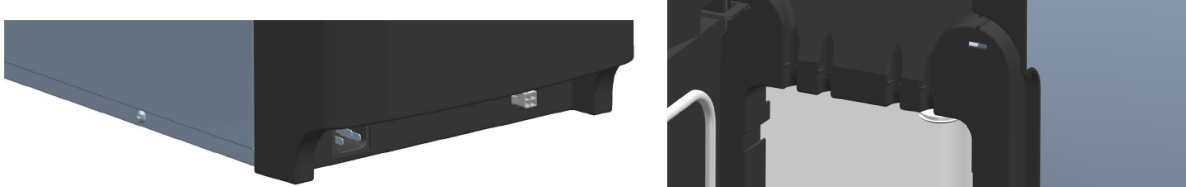

Fig.4

The refrigerator must be used only with the provided tank, in any case with closed milk containers.

The refrigerator is provided of a digital thermostat placed on the frontal panel.



Refrigerator switch on





When the refrigerator is switched on, but in standby mode, the thermostat's display shows alternatively "OFF" and the inside temperature value.

To turn on the refrigerator, hold the button  pushed for at least 3 seconds. You will see "ON" on the display and immediately after the inside temperature value.

Once turned on, the fridge will start working, but it will take some time (also depending on external conditions) to reach the required internal temperature.

We recommended to put milk inside the refrigerator only when the internal temperature has stabilized to the required value.

Temperature setting

To set the desired temperature, push the button  until you see the current set point value flashing, then adjust the value using the button  (increase) and  (decrease); to store the new value press the button .

NOTE: *To ensure that the milk is always maintained at temperature allowed by the HACCP, the setpoint can be varied only within a specific values range.*

NOTE: *The refrigerator can operate at lower temperatures than the level obtained, by setting the thermostat to lower setpoint values. However, since these temperatures are out of the envisaged range for storing milk or similar liquids for human consumption, the manufacturer advises against using the refrigerator in this way, stressing again that the appliance is designed and made to store milk or similar liquids for human consumption at a controlled temperature and not to chill such products from room temperature.*

Milk level sensor functioning

The refrigerator is provided with one milk level sensor which detects the presence of milk in the container and generates an alarm when the level falls below about 0.5 litres of milk. The refrigerator can be provided also with two milk level sensors (optional) to be used with milk tank with wall divider (for two milk kind).

The refrigerator needs to be connected to the coffee machine, the milk level alarm will be shown on the coffee machine display.

NOTE: *This refrigerator is designed to work with a full milk container placed inside it. In this way, if the refrigerator is working without the container or with a small amount of milk, the alarm will activate.*

Refrigerator switch off

To switch off the refrigerator hold the button  for at least 3 seconds.

7.5 Defrosting

If the refrigerator is left to operate for very long periods of time, it is possible for ice to form on its inside walls.

If the ice becomes considerably thick, it is advisable to defrost the refrigerator in order to continue to guarantee good appliance efficiency and avoid higher electricity consumption.

To defrost the appliance, switch it off, holding the button  of the thermostat for at least 3 seconds; we recommend leaving the refrigerator door open to speed up this operation.

Never use tools or utensils of any type to remove ice as this could damage the evaporator, which is in contact with the inside walls of the refrigerator.

The manufacturer cannot accept any liability for damage to the appliance caused by failure to abide by this recommendation.

NOTE: *During defrosting operation, do not leave the milk container inside the refrigerator.*

At the end of the defrosting operation, after cleaning and thoroughly drying the insides of the refrigerator, switch it on holding button  of the thermostat for at least 3 seconds.

7.6 Installation of milk tube

The milk pumping system of Center Cooler is the assembly of following components:

- Milk Tank (1);
- Silicon tube (2);
- Milk tube connection (3);
- Milk tank cap (4);
- Milk tube;

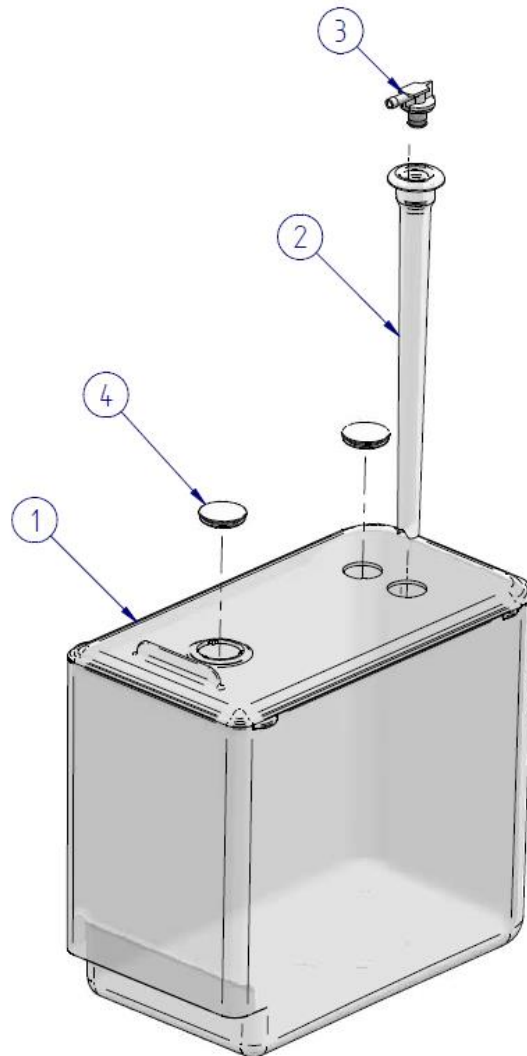

Fig.5

You can use the Center Cooler refrigerator with a single coffee machine or with two coffee machines. In the first case, insert the silicon tube (2) and the milk tank caps (4) as in the figure 6A, while in the second case use two silicon tubes (2) and the milk tank cap (4) as in the figure 6B.

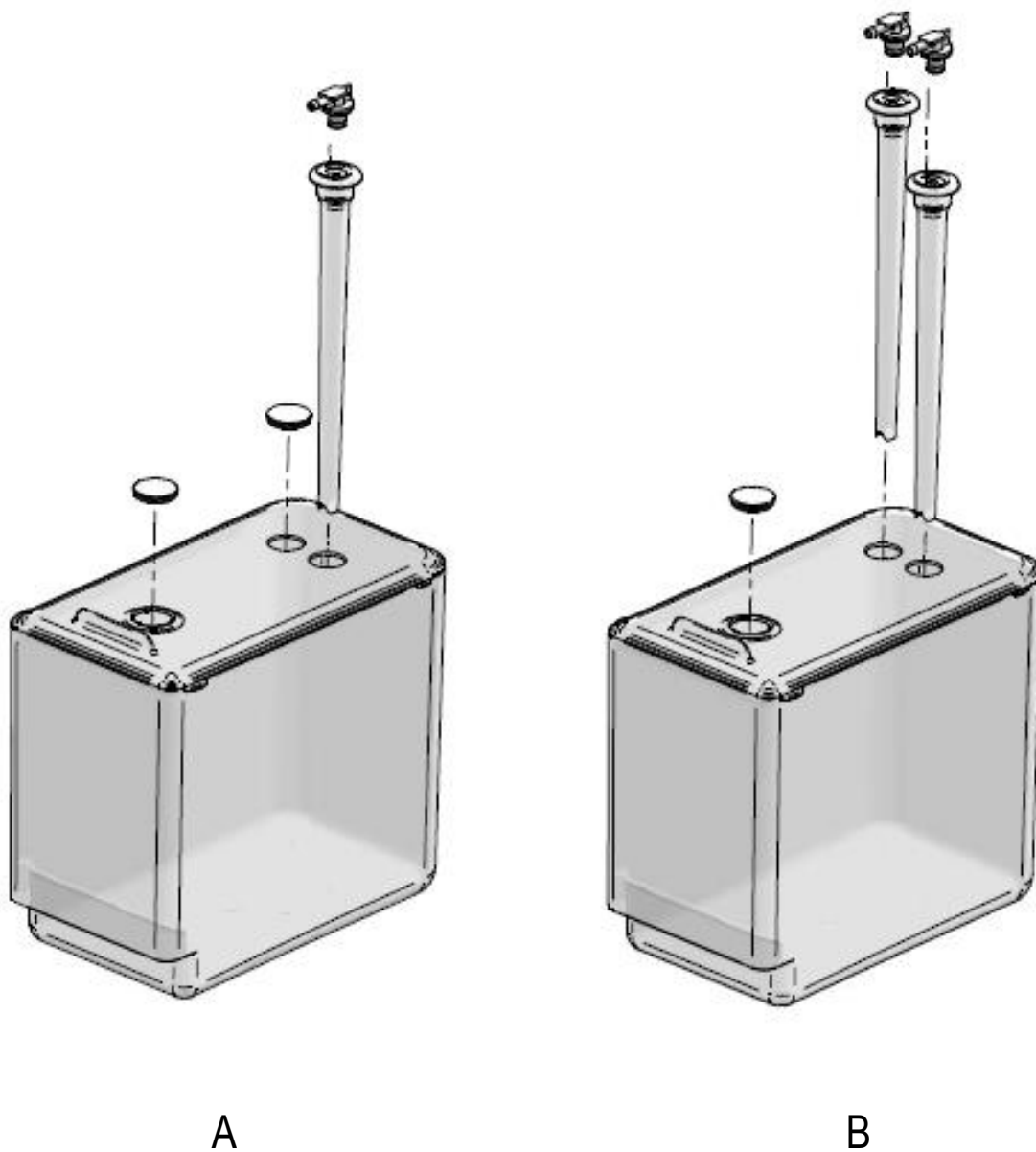

Fig. 6

In all applications of Center Cooler showed in the figure 6, insert the milk tube connection in the hole of silicon tubes, with the milk tube pre-assembled (figure 7).

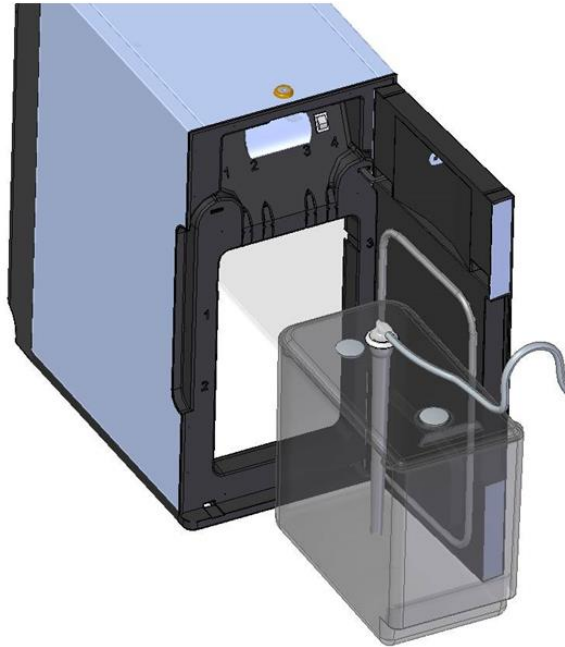

Fig. 7

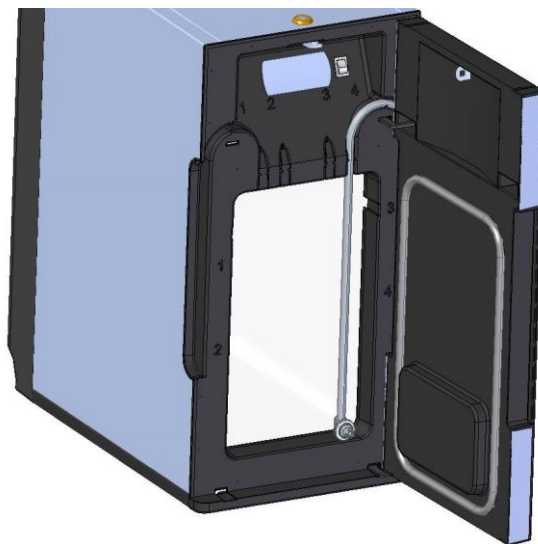

Fig.8

Setting the right length for the milk tube. The milk tube with the connector needs to reach the bottom of the cooler.

In the figure 9 is showed the specific passage for the milk tube, in orange the passage where the milk tube must be blocked. Push the milk tube until the end surface of black frontal.

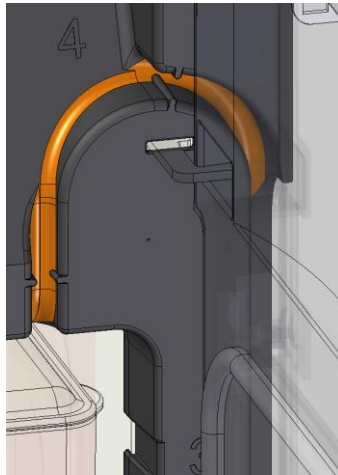

Fig. 9

In the black frontal of Center Cooler there are four slot tubes, and the slot are highlight in orange in the figure 10.

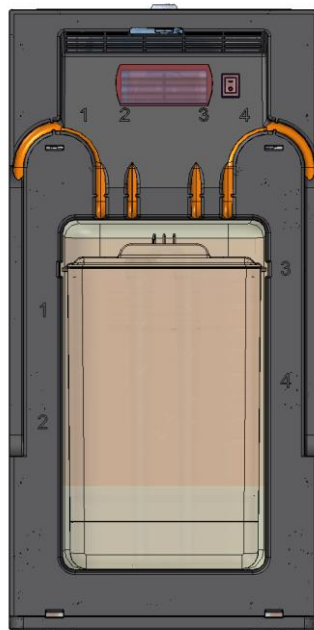

Fig. 10

If the Center Cooler is used with 2 coffee machines, you need to use the slots number 1 and 4 showed in the black frontal (figure 10). If the Center Cooler is used with just one coffee machine, you need to use slot 1 or 4 depending on the relative position of the cooler respect to the machine.

Three silicone caps are provided as accessories (figure 11).



Fig. 11

The silicone caps must be placed in the unused slots, as is showed in the figure 12.

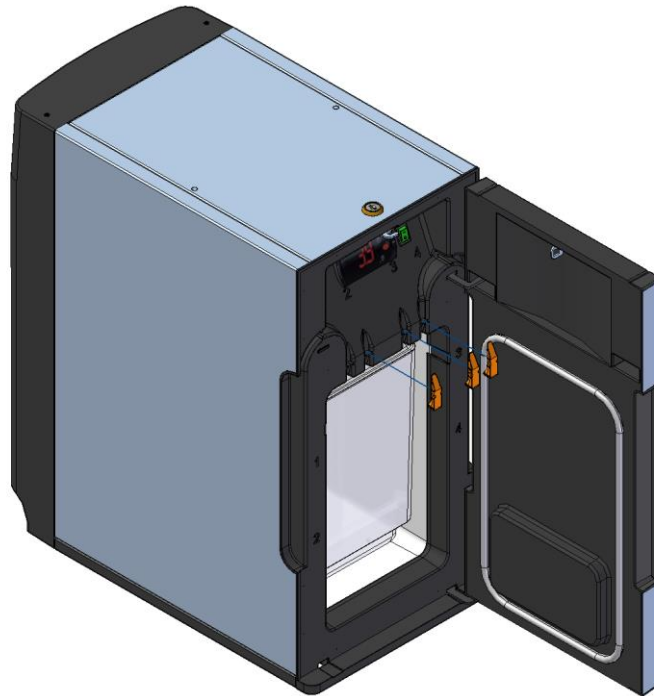

Fig. 12

It's important that the silicone caps are used in the unused slots, because if they are not present in the refrigerator, you will have cold air losses. When you have done the operations specified in this section of the manual, close the door of refrigerator and connect the milk tube at the coffee machine.

7.7 Cleaning and maintenance

Under the current regulations regarding health and safety, the operator is responsible for the hygiene of food contact materials and must maintain and clean the unit, preventing the bacteria formation.



CAUTION
Disconnect from supply
source before servicing

Before performing any cleaning and / or maintenance operation, disconnect the electrical supply to the refrigerator.

This important information is written on a plate placed on the back of the product.

It's good practice use sanitizing products for cleaning surfaces not directly in contact with food.

The outside of the refrigerator (painted steel and/or painted plastic) can be washed first with warm water and then rinsed in cold water and dried with a soft cloth. Do not use abrasive products.

To clean the inside of the refrigerator, after removing any containers of milk or similar liquids for human consumption, wipe with warm water and if necessary, a little vinegar to remove any grease. Rinse with clean water and dry with a soft cloth. Never use abrasive products, detergents or soap.

It is recommended to clean the internal part of the milk cooler's door (areas highlighted in the picture below) using the brush supplied together with the cooler.

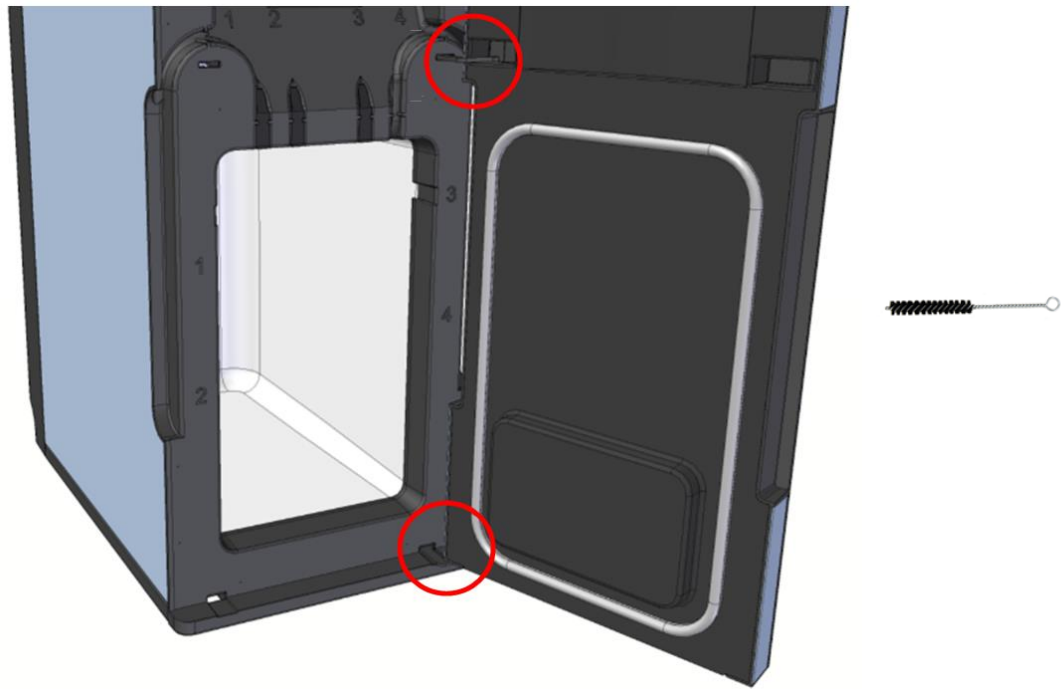

Fig. 13

It is also advisable to make sure that the air-cooled condenser of the refrigerating unit at the back of the appliance is clean. If it is particularly clogged with dust, this should be removed using a vacuum cleaner.

In case of a prolonged period of disuse, we advise you to disconnect the refrigerator from the power supply, empty it completely, clean it and leave the door slightly open to prevent the formation of mould and/or unpleasant odours.

7.8 Non-ordinary maintenance and service operation

Servicing and maintenance operation on the refrigerator must be ensured and performed by qualified service personnel only.

Access to the service area is permitted only for persons with knowledge and practical experience with the unit, especially regarding safety and hygiene. They need to be equipped with the right personal safety devices.

The refrigerator must be set up such that care and maintenance are not hindered.

8 Disposal

If the refrigerator needs to be placed out of service, it must not be disposed of as household waste but taken to a refuse recycling centre. This is shown by the  symbol on the product label.

Use specialist waste collection centres that are certified according to current standards.

If not correctly disposed of, the product can be harmful to the environment because of the specific substances it contains.

The refrigerant inside the system must not be disposed of with normal waste.

Incorrect disposal or illegal dumping of the product will lead to severe legal penalties of an administrative and/or criminal nature, as envisaged by current laws.

9 Warranty Claims

The warranty period starts from the date of delivery to the final user.

The vendor should always be afforded the opportunity to rectify errors within an appropriate period.

Claims that exceed the above terms, in particular damage claims as a result of consequential damage, are excluded to the extent that this is legally permissible.

Material defects shall be reported to the vendor immediately and in writing.

No warranty is provided:

- on any parts subject to natural wear and tear. These include the milk container, the parts carrying milk and the front door's seal.
- for malfunctions due to the effect of the weather, chemical, electrochemical or electrical effects.
- if malfunctions occur as a result of failure to follow handling instructions and regulations, maintenance and care of the unit.
- if malfunctions occur as the result of use non original replacement parts or incorrect assembly by the purchaser or by third parties or by faulty or negligent treatment.
- if improper modifications are made without our consent or in case of repair or reconditioning work on the part of the purchaser or by third parties.
- in respect of faults caused by inappropriate or improper use.

10 Troubleshooting

The following table serves to provide some suggestions concerning the checks to be made in case of incorrect refrigerator operation.

If, after completing the suggested checks, the refrigerator is still not operating regularly, contact your nearest assistance service.

Problem	Possible cause	Solution
The refrigerator will not start	Power supply	Make sure that the power cord is correctly plugged into the power socket Make sure the main power switch is on "I" position Make sure that the automatic breaker on the system's electrical panel is on Make sure that the plug socket is working Make sure that the power cord is not damaged and/or broken
	Thermostat	Make sure that the digital thermostat is set to ON
The refrigerator is noisy	Position	Make sure that the refrigerator has been properly levelled Make sure that the refrigerator is not in contact with furniture or other items that might increase its vibrations

	Refrigerant pipes	Make sure that the pipes and/or components of the refrigerant circuit are not touching. This is a check that must only be carried out by a specialist service technician
The cooling power of the refrigerator is not enough	Door closure	Make sure that the door is correctly closed and also that the gasket is not damaged in any point
	Position	Make sure that the refrigerator is not too close to heat source
	Condenser	Make sure that the refrigerator is positioned so that the condensation air can be discharged correctly (from the rear panel)
		Make sure that the condenser fan is rotating correctly
		Check the condenser for dust and clean if necessary
Defrosting	Make sure that the insides of the refrigerator are not covered in ice. Defrost if necessary	
General	Make sure that only precooled milk is filled in	
	Do not place any hot or warm container in the cooler (danger of breaking inner liner)	
	Make sure that the milk hose does not touch the inner liner walls.	